

# VXI-SC-1000 CARRIER MODULE

This guide describes how to assemble, configure, and install the VXI-SC-1000 carrier module with any of the VXI-SC submodules.

## Introduction

---

The VXI-SC-1000 carrier module provides a VXI interface and serial peripheral interface for two separate VXI signal conditioning submodules. The VXI-SC-1000 carrier module and the associated VXI-signal conditioning (VXI-SC) submodules can condition signals for thermocouples, RTDs, strain gauges, thermistors, millivolt sources, volt sources, and current-loop receivers.

The VXI-SC-1000 is part of the VXI signal conditioning system, which consists of the components listed below and shown in Figure 1.

- The VXI-SC-1000 is a carrier module that installs into a slot in a VXIbus chassis. The VXI-SC-1000 is populated with one or two VXI-SC submodules.
- The VXI-SC submodules install into VXI-SC subslots on a VXI-SC-1000 carrier module. Some submodules, such as the VXI-SC-1150 use Signal Conditioning minipods (SCMPs), small modular boards that install into SCMP sockets.

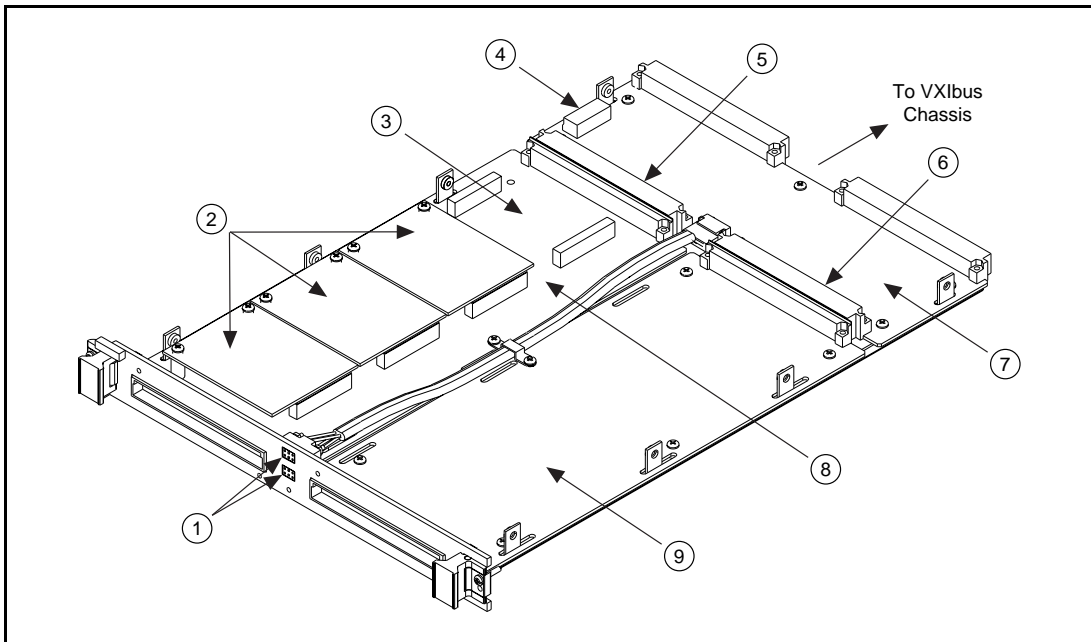

1 Analog Bus Receptacle	4 Logical Address Switch	7 VXI-SC -1000 Carrier Module
2 SCMPs	5 VXI-SC Subslot 1	8 VXI-SC-1150 Submodule
3 SCMP Socket	6 VXI-SC Subslot 2	9 VXI-SC Submodule

**Figure 1.** Components of a VXI Signal Conditioning System

Your VXI-SC-1000 carrier module is shipped with a filler panel installed in one of the submodule sites. This filler panel is for applications where only one VXI-SC submodule will be installed. You should leave the filler panel in place until you are ready to replace it with a VXI-SC submodule.

The VXI-SC-1000 carrier module and VXI-SC submodules work with a VXI-MIO module. When used with the VXI-SC-1000, the VXI-MIO module controls the VXI-SC-1000 and its components through an interface similar to that of SCXI. The VXI-MIO module can control both an external SCXI chassis (through the front panel connector) and an internal VXI-SC-1000 carrier module (through the VXI local bus) to create a complete signal conditioning solution. The VXI-MIO module can control multiple VXI-SC-1000 carrier modules up to the maximum slot depth of the VXIbus chassis.

# What You Need to Get Started

---

To set up and use your VXI-SC-1000, you will need the following items:

- VXI-SC-1000 carrier module
- VXI-SC-1000 Carrier Module Installation Guide*
- Hardware kit
  - Analog bus jumper
  - 7 No. 4-40 panhead screws
  - 6 No. 4-40 flathead screws
  - Analog bus cable clamp
- VXIbus chassis
- VXI-MIO module and documentation
- One or two VXI-SC submodules and documentation
- Phillips-head number 1 screwdriver
- SCXI chassis and documentation (optional)
- TBX cable (optional)
- VXI-TB-1000 and documentation (optional)

## Installation

---

### Installing the First VXI-SC Submodule

Your VXI-SC-1000 requires three different types of screws for assembly. Some of these screws are supplied in the hardware kit shipped with your VXI-SC-1000; others are already attached to the carrier module. Figure 2 shows these screws in greater detail to help you distinguish among them.

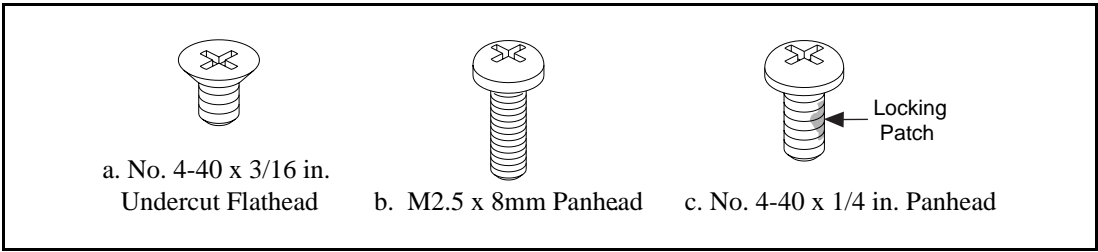

**Figure 2.** Assembly Screws

Use the following procedure to install your first VXI-SC submodule.

1. To remove the top cover, remove the two flathead screws that hold the top cover in place and lift the cover straight up. Keep the screws in a safe place; you will need them to complete your assembly. See Figure 3 for the locations of these screws.

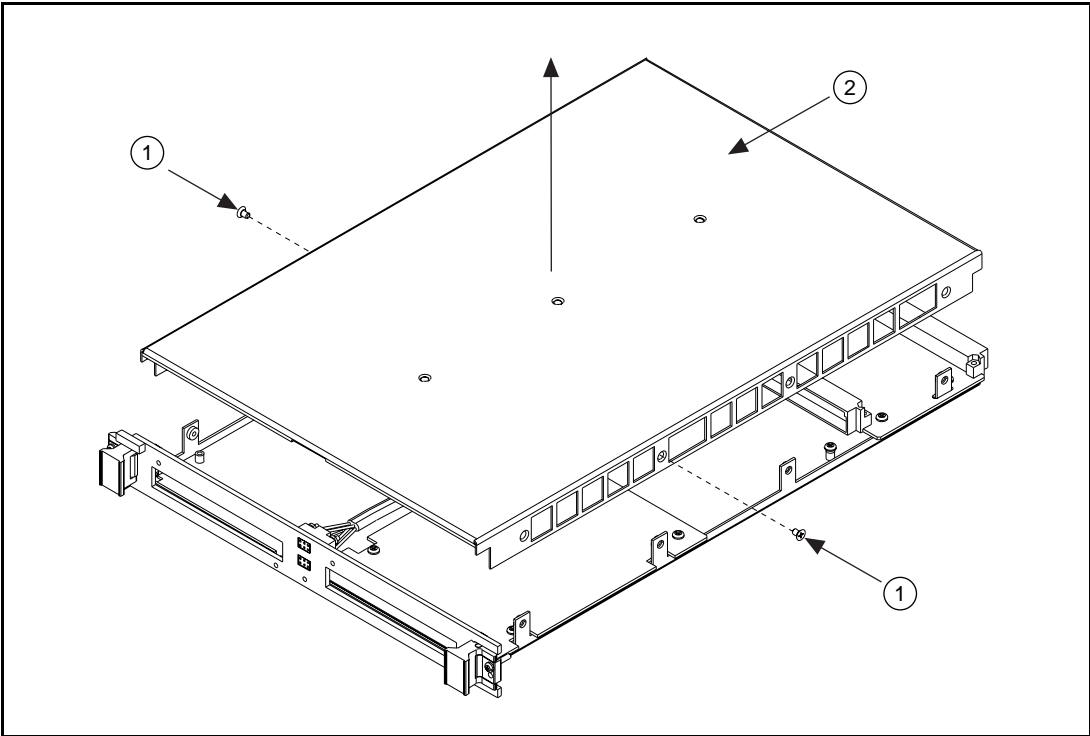

1 No. 4-40 x 3/16 in. Flathead Screws      2 Top Cover

**Figure 3.** Removing the VXI-SC-1000 Cover

2. Remove the front panel/cable assembly, referring to Figure 4 as necessary. Disconnect the analog bus cable connector (item 2) from the rear of the carrier module. Remove the two M2.5 screws (item 4) holding the front panel to the filler panel (item 3). Keep the screws in a safe place; you will need them to complete your assembly.



**Note:** *One of the two M2.5 screws (item 4) was used to hold your VXI-SC-1000 carrier module together for shipping. You will use this screw later in a different location.*

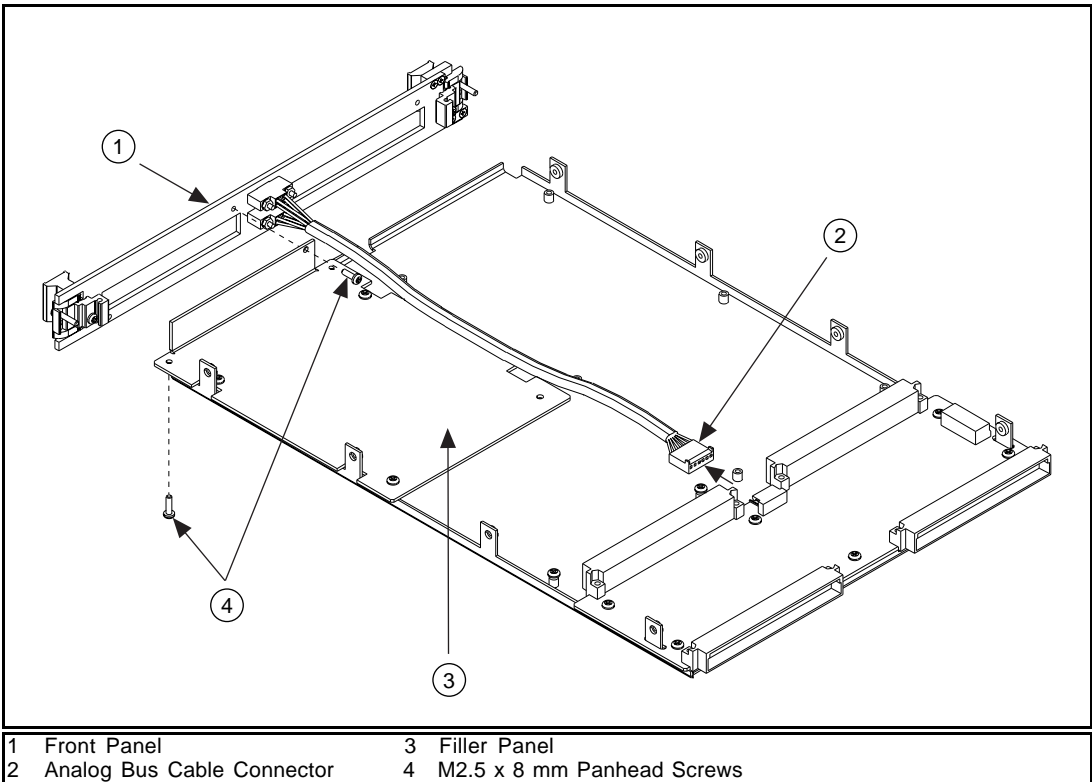

**Figure 4.** Removing the Front Panel Assembly

3. To install your VXI-SC submodule, insert the submodule into the carrier and firmly slide it into place, fully seating the connector. Remove five of the No. 4-40 panhead screws from your hardware kit and use them to secure the VXI-SC submodule to the carrier module. See Figure 5, item 1.

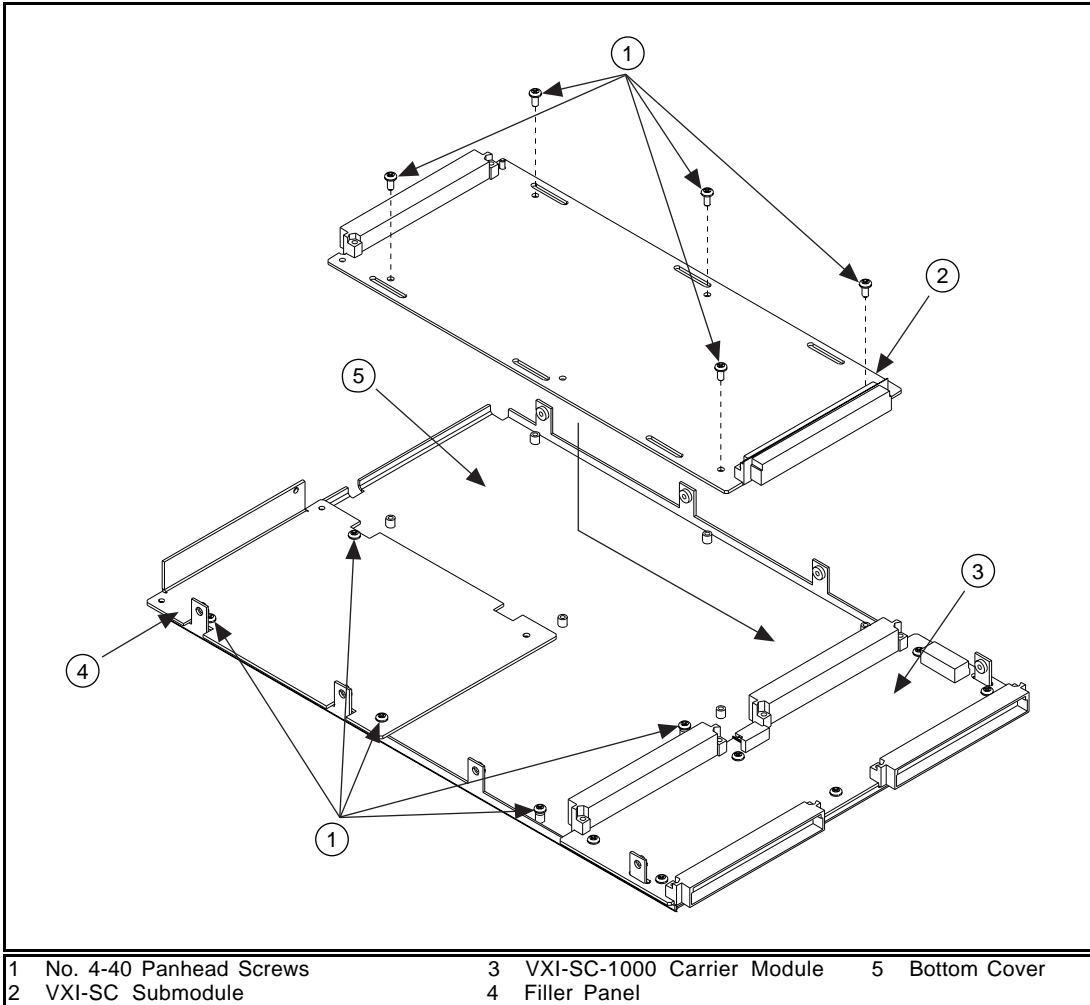

**Figure 5.** Installing a VXI-SC Submodule

If you are installing a second submodule, remove the filler panel (Figure 5, item 4) by removing the three mounting screws (item 1). Remove the two extra mounting screws that are already installed. Use these five screws to install the second submodule.



**Note:** *If you are installing only one submodule, do not remove the filler panel.*

4. To re-install the front panel assembly, use the two M2.5 screws that you removed in Step 2 and attach the front panel/cable assembly as shown in Figure 6.

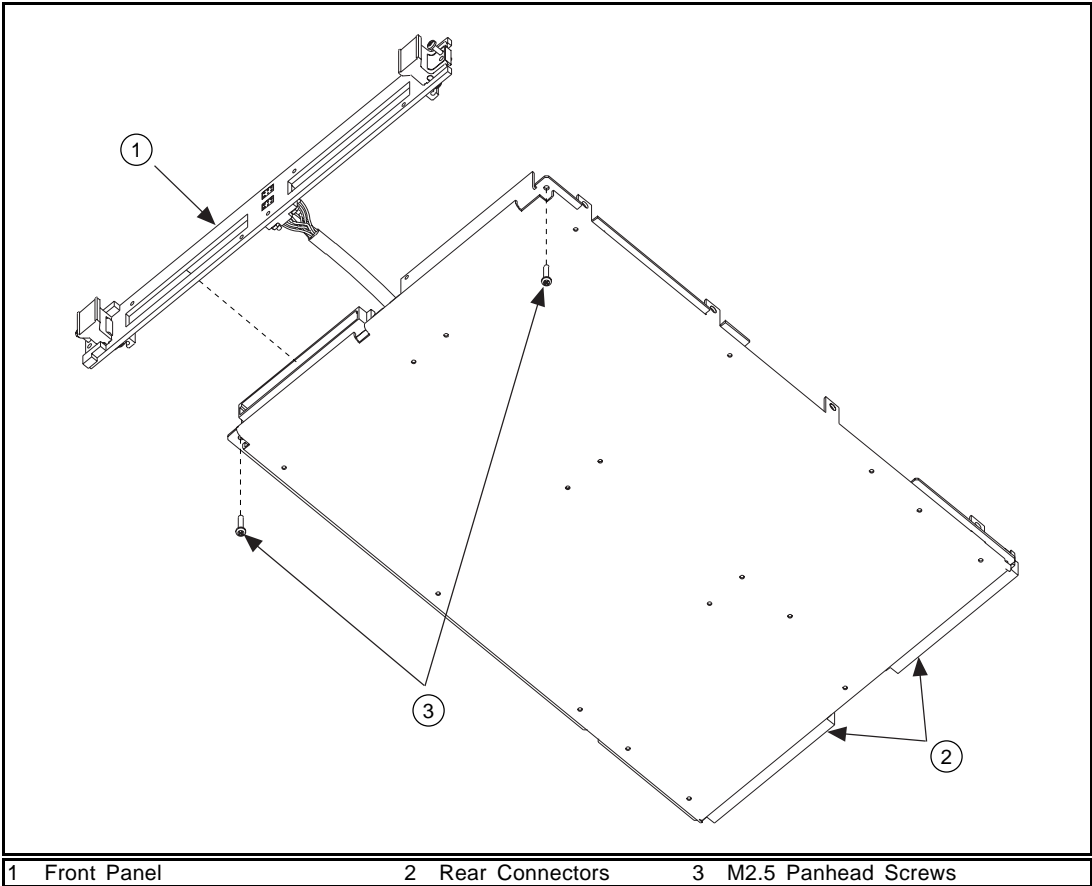

**Figure 6.** Re-installing the Front Panel Assembly (bottom view)

5. Reconnect the analog bus cable connector (Figure 7, item 3) to the rear of the carrier board as shown. Install the cable clamp (item 2) using two No. 4-40 panhead screws (item 1) supplied in your hardware kit.

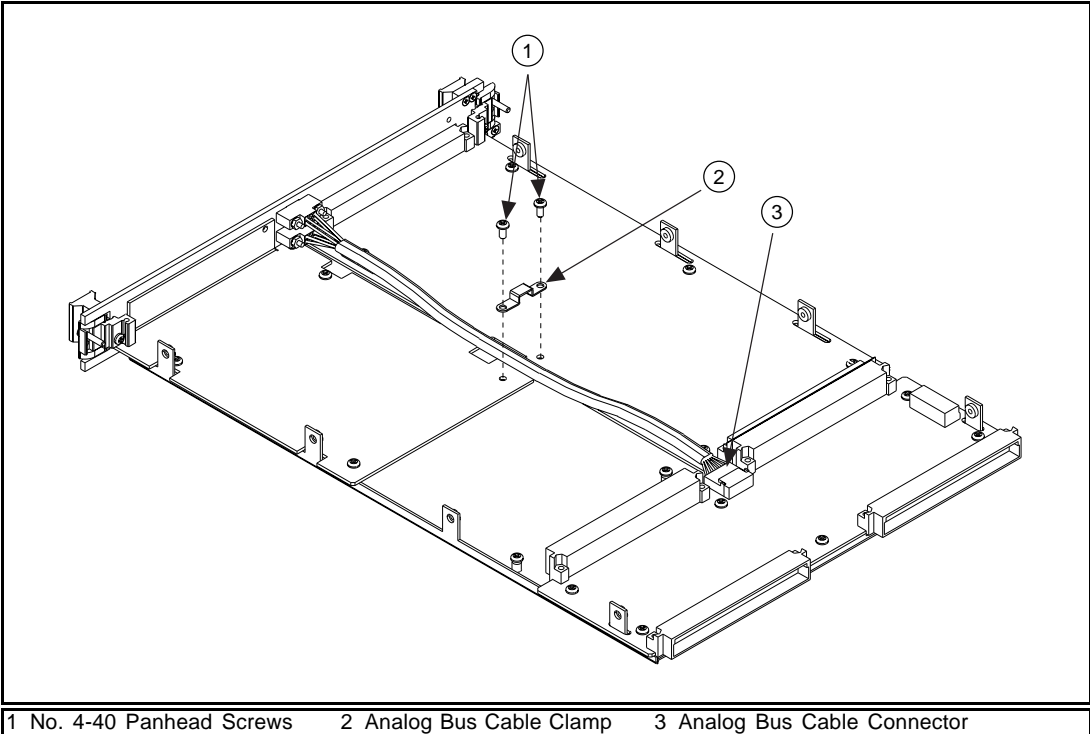
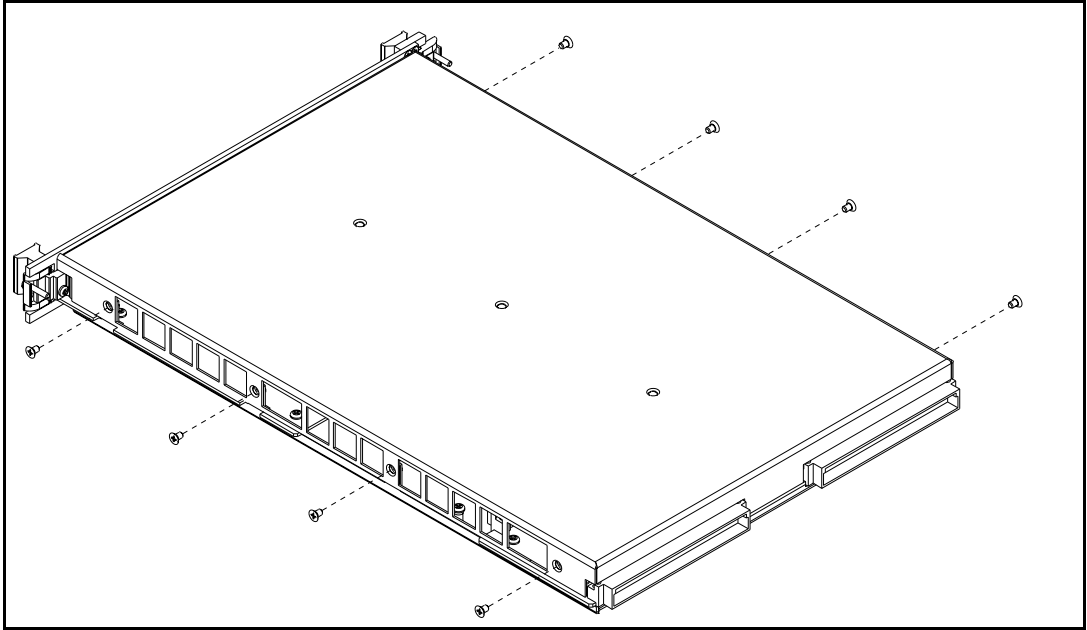

**Figure 7.** Installing the Analog Bus Cable and Clamp



- Using the eight flathead screws shown in Figure 8, secure the top cover to the VXI-SC-1000 carrier module.

 **Note:** *Extra screws may be provided. Do not be concerned if, after you complete the installation, you have left-over screws.*



**Figure 8.** Re-installing the Top cover

 **Note:** *Your VXI-SC submodule comes with a small identification label that you can place on the front panel to record which submodules are installed.*

## Adding or Replacing a VXI-SC Submodule

Refer to Steps 3–6 and Figures 5–8 in reverse order to replace either the filler panel or an existing VXI-SC submodule with a new VXI-SC submodule. All necessary hardware items should already be installed in your VXI-SC-1000 carrier module.

 **Note:** *There should always be a filler panel or a submodule in subslot 1.*

# Configuring Your VXI-SC-1000

---

The VXI-SC-1000 is software-configurable, except for the VXIbus logical address. To configure the VXI-SC-1000 logical address, refer to Figure 9 as needed and read the following section.

## VXIbus Logical Address

Each module in a VXIbus system is assigned a unique number between 0 and 254. This 8-bit number, called the logical address, defines the base address for the VXIbus configuration registers located on the module. With unique logical addresses, each VXIbus module in the system is assigned 64 bytes of configuration space in the upper 16 KB of the A16 address space.

Logical address 0 is reserved for the Resource Manager in the VXIbus system. Because the VXI-SC-1000 cannot act as a Resource Manager, do not configure the VXI-SC-1000 with a logical address of 0. The factory-default logical address for the VXI-SC-1000 is 8.

Some VXIbus modules have dynamically configurable logical addresses. These modules have an initial logical address of hex FF or decimal 255, which indicates that they can be dynamically configured. Your VXI-SC-1000 carrier module supports dynamic configuration of its logical address.

Ensure that no other statically configurable VXIbus modules have the same logical address as the VXI-SC-1000. If they do, change the logical address setting of either the VXI-SC-1000 or the other module so that every module in the system has a different associated logical address. Pay special attention to the logical address when installing multiple VXI-SC-1000 modules because initially they will all have the same factory-set address.

You can set the VXI-SC-1000 logical addresses to 255 and let the Resource Manager dynamically allocate your VXI-SC-1000 logical address.

To change the logical address of the VXI-SC-1000, modify the setting of the 8-bit DIP switch (see Figure x) labeled LOGICAL ADDRESS SWITCH (U11). The down position of the DIP switch corresponds to a logic value of 0 and the up position corresponds to a logic value of 1.

The assembled VXI-SC module is designed to act as three separate VXI modules and, therefore, uses a block of four logical addresses. When statically setting a logical address, do not use the lowest two bits, A0 and A1. The VXI-SC-1000 uses the first logical address to access all of the VXI registers associated with the module. The second and third logical addresses are used for the VXI-SC submodules. The fourth address simply does not respond to any VXI accesses. The lowest two bits should be switched to 1 only when the logical address is 255 (for dynamic configuration).

The logical addresses associated with the submodules respond to VXI accesses only when a submodule is actually plugged into a subslot. If no submodule is present, that address will not respond to VXI accesses. When a submodule is present, all of the first address registers are aliased except the device ID, which is unique to that particular VXI-SC submodule. For compatibility across all resource managers, install your VXI-SC submodule in subslot 1 first; if an additional submodule is required, plug it into subslot 2. With these features in place, the VXI Resource Manager can identify not only the VXI-SC-1000 carrier module, but also the associated submodules. Figure 10 shows the VXI-SC-1000 carrier module switch settings for logical address 8 and 255.

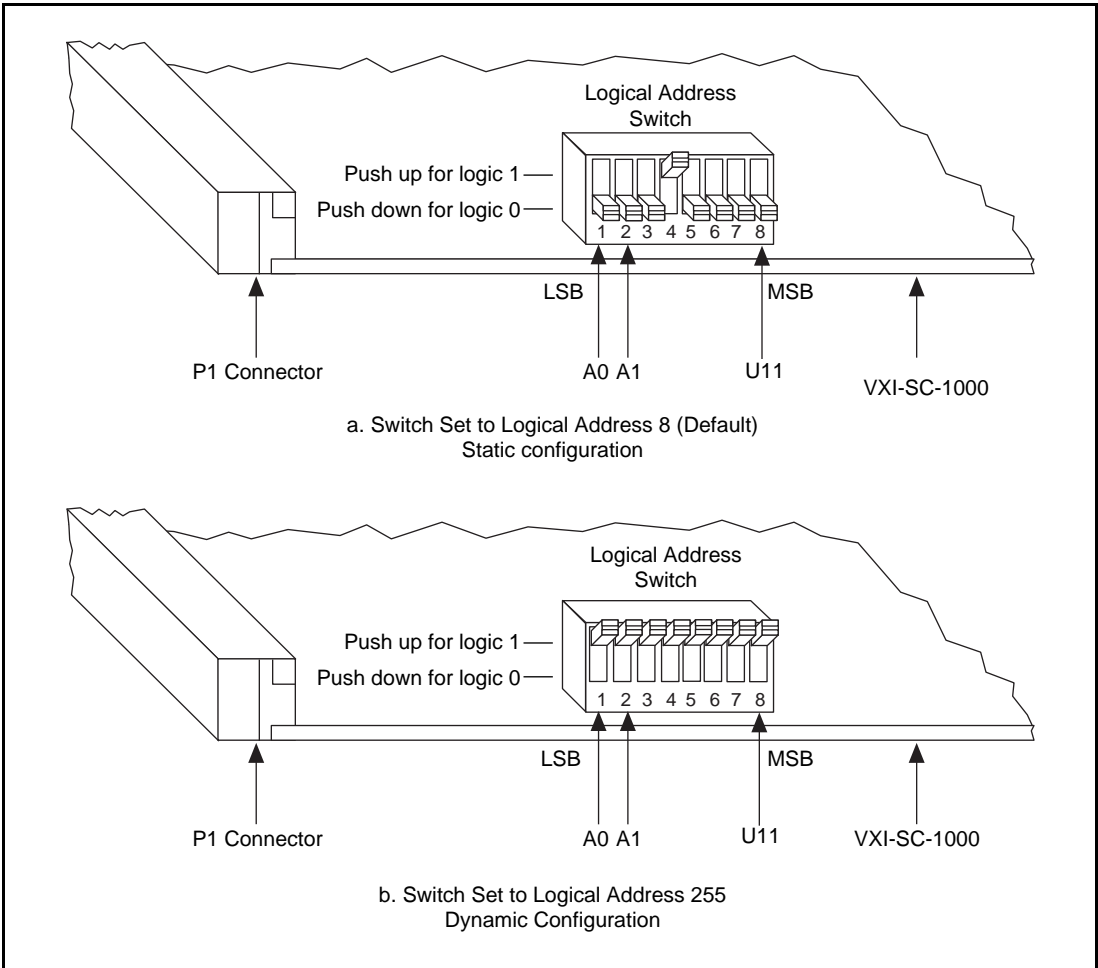

**Figure 9.** VXI-SC-1000 Logical Address Selection

You can now install the VXI-SC-1000 into your VXIbus chassis.

# Installing the VXI-SC-1000 into Your VXIbus Chassis

---

When the VXI-SC-1000 carrier module and corresponding VXI-SC submodules are assembled, you can install the assembled module into the VXIbus chassis. Perform the following steps:

1. Insert the VXI-SC-1000 into the VXIbus chassis and press firmly until the connectors mate securely.
  - a. Select the VXI slot closest to the right of the VXI-MIO module or VXI-SC-1000 carrier module. The VXIbus local bus maintains the serial communication, and there can be no empty slots between any VXI-MIO modules and the VXI-SC-1000 carrier module or between any two VXI-SC-1000 carrier modules. The VXI-MIO module and the VXI-SC-1000 carrier modules must be placed contiguously.
  - b. Do not overlook the mechanical key feature. The VXI specification makes provisions for a mechanical key to prevent incompatible systems from connecting through the local bus. If a module does not fit properly, do not remove the key. Move the incompatible module over by one slot.
2. If you are using an analog bus jumper, attach it as shown in Figure 10. Secure the jumper by tightening the retaining screw. The analog bus jumper propagates the analog signals from the VXI-SC submodules back to the VXI-MIO module.
3. Refer to the documentation supplied with your VXI-TB-1000 or TBX cables for bringing signals into the front connectors of your VXI-SC-1000.

The installation is complete.

If at power-up the Resource Manager detects a conflict, change the logical address of one of the conflicting boards to an address different from all the rest.

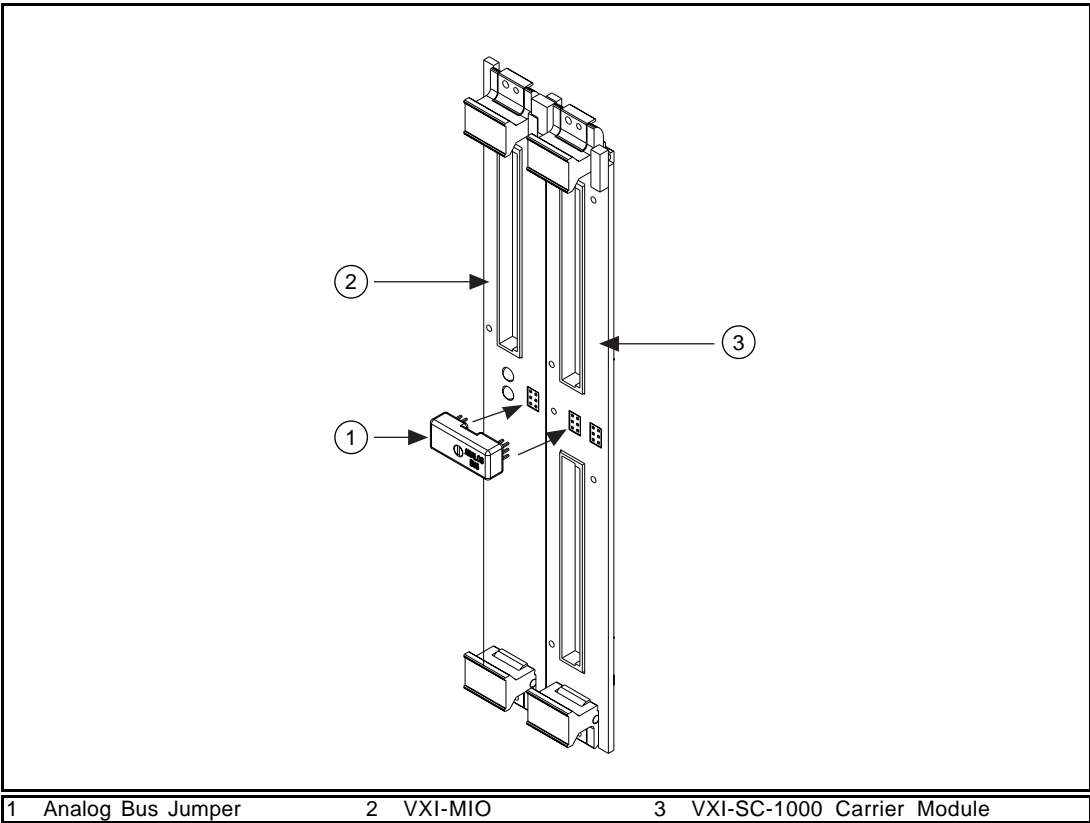

**Figure 10.** Installing the Analog Bus Jumper

## Specifications

### Power Requirement

+5 VDC.....0.15 A typ, 0.25 A max\*  
 (\*not including current used by submodules)

All VXI power supplies are made available to the VXI-SC modules, and each of the two modules can draw the current shown in Table 1 from each supply.

**Table 1.** Maximum Power Available per Submodule

<b>Power</b>	<b>Maximum Current</b>
+5.0 V	625 mA
-5.2 V	250 mA
+PWR*	180 mA
-PWR*	180 mA
+12.0 V	250 mA
-12.0 V	180 mA
-2.0 V	250 mA
* These supplies are derived from $\pm 24$ V and go through 4 diode drops to produce $\sim \pm 20.5$ V.	

The maximum current draw is based on the number of connector pins passing power, total current available, and an ambient temperature of 70° C. Note that at 70° C the fuse derates to 50% of its ambient 25° C current carrying capacity.

## Physical

Dimensions .....VXI C-size single slot

## Environment

Operating conditions

Temperature .....0° to 55° C

Relative humidity.....5% to 90% noncondensing

Storage conditions

Temperature .....-20° to 70° C

Relative humidity.....5% to 90% noncondensing



321377A-01  
January 1997